

# 5028-I

# Straight Blade Wiring Devices



UPC Code: 07847777357

Country of Origin: United States - \*Eligible for ARRA funded projects

NEMA: 6-15R

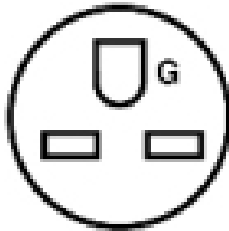

\*May include one or more globally sourced components.



## Brand Features

Leviton's line of Heavy-Duty Specification Grade receptacles are designed and manufactured to withstand the most demanding environments. Available in a wide variety of configurations, including isolated ground, tamper-resistant, etc., these Commercial Grade devices are the electrical contractor's choice for use in hotels, schools, hospitals and commercial office buildings.

## Item Description

15 Amp, 250 Volt, NEMA 6-15R, 2P, 3W, Narrow Body Duplex Receptacle, Straight Blade, Commercial Grade, Self Grounding, Canadian, , Side Wired, Steel Strap, - Ivory

## Technical Information

### AC Horsepower Ratings

**At Rated Voltage:** 1-1/2 HP

### Electrical Specifications

**Grounding:** Self-Grounding

**Amperage:** 15 Amp

**Voltage:** 250 Volt

**NEMA:** 6-15R

**Pole:** 2

**Wire:** 3

**Dielectric Voltage:** Withstands 2000V per UL498

**Current Limiting:** Full Rated Current

**Temperature Rise:** Max 30C after 100 cycles OL at 150 percent rated current

### Environmental Specifications

**Flammability:** Rated V-2 per UL94

**Operating Temperature:** -40C to 60C

### Material Specifications

**Face Material:** Nylon

**Body Material:** Nylon

**Line Contacts:** Brass Double Wipe .031 Thick

**Terminal Screws:** Brass 8-32

**Grounding Screw:** Brass 8-32

**Strap Material:** Zinc-Plated Steel

**Ground Clips:** Brass-Plated

**Color:** Ivory

### Mechanical Specifications

**Terminal ID:** Brass-Hot, Green-Ground, White-Neutral

**Terminal ID:** Brass-Hot, Green-Ground, Silver-Neutral

**Terminal Accom.:** 14-10 AWG

**Product ID:** Ratings are permanently marked on device

**Termination:** Side

### Product Features

**Grounding:** Self Grounding

**NEMA:** 6-15R

**Color:** Ivory

### Standards and Certifications

**NEMA:** WD-2 WD-6

**ANSI:** C-73

**UL498:** File E13399

**UL Fed Spec WC-596:** File E13399

**CSA C22.2 No. 42:** File 152105

**NOM:** 057

**Warranty:** 10 Year Limited

## Dimensional Diagram

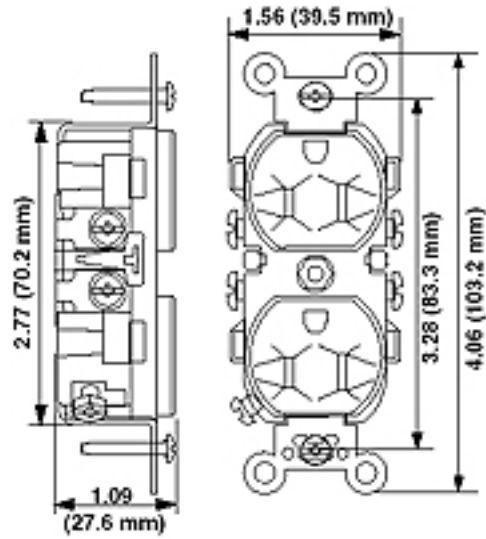

## Wiring Diagram

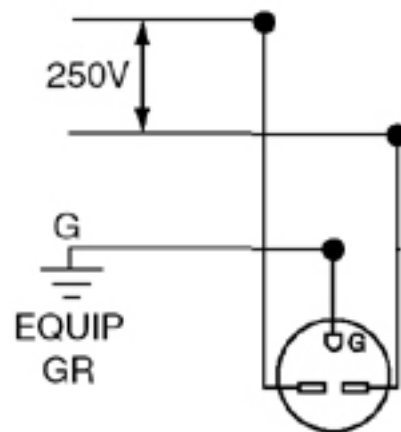

6-15R

### SPECIFICATION SUBMITTAL

JOB NAME: <input type="text"/>	CATALOG NUMBERS: <input type="text"/>	
JOB NUMBER: <input type="text"/>	<input type="text"/>	<input type="text"/>

**Leviton Manufacturing Co., Inc.**

201 North Service Road, Melville, NY 11747

Telephone: 1-800-323-8920 · FAX: 1-800-832-9538 · Tech Line (8:30AM-7:30PM E.S.T. Monday-Friday): 1-800-824-3005

**Leviton Manufacturing of Canada, Ltd.**

165 Hymus Boulevard, Pointe Claire, Quebec H9R 1E9 · Telephone: 1-800-469-7890 ·

FAX: 1-800-824-3005 · [www.leviton.com/canada](http://www.leviton.com/canada)

**Leviton S. de R.L. de C.V.**

Lago Tana 43, Mexico DF, Mexico CP 11290 · Tel.: (+52)55-5082-1040 · FAX: (+52)5386-1797 · [www.leviton.com.mx](http://www.leviton.com.mx)

**Visit our Website at: [www.leviton.com](http://www.leviton.com)**

© 2012-2015 Leviton Manufacturing Co., Inc. All rights reserved. Subject to change without notice.



**Leviton has a global presence.**

If you would like to know where your local Leviton office is located please go to: [www.leviton.com/international/contacts/](http://www.leviton.com/international/contacts/)

*\*Buy American Compliant Logo -- The American Recovery And Reinvestment Act of 2009 ("ARRA") provides federal grants and loans for projects throughout the country. Section 1605 of the Act, named the "Buy American" provision, requires that certain materials and manufactured products used in projects funded by the Act be manufactured in the United States. The appearance of the Recovery Act Logo in relation to a Leviton product is only intended to reflect that such product may be used in an ARRA funded project. It does not mean that such product or Leviton is sponsored or endorsed by, or that Leviton receives funds from, the federal government or the Recovery Accountability and Transparency Board. Nothing in Leviton's use of the logo is intended to suggest anything regarding the requirements for funding under ARRA.*